

Article number: 201605111

Description: Lock nut ISO 8675 B-M10x1 Stainless

Measures

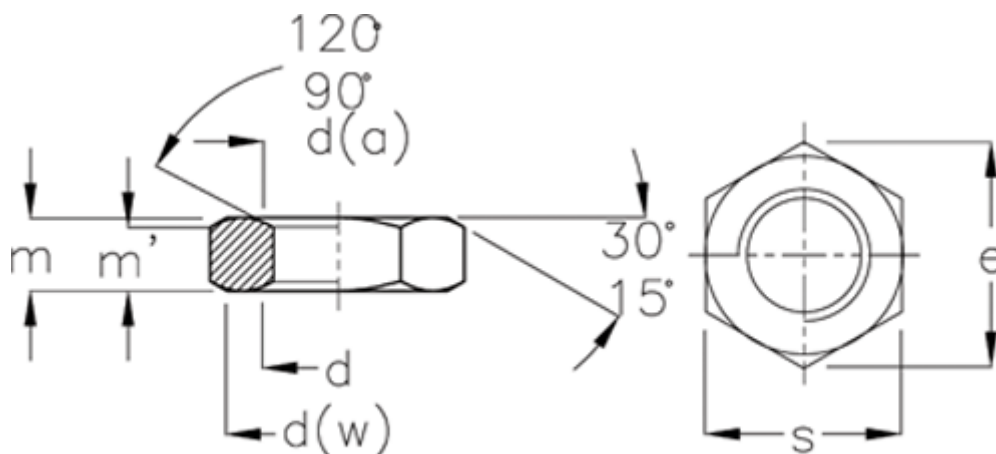

d	= M10	m min	= 4.70
d1 max	= 10.8	s max	= 16
d1 min	= 10	s min	= 15.73
d2	= M10	Thread pitch	= 1.0
d3	= 1.0	w	= 14.63
e	= 17.77		
m	= 3.76		
m max	= 5		